

# IAI

Quality and Innovation

Slider Type

Rod Type

ROBO Cylinder®

# RCP4-SA3/RA3

Cleanroom Type

# RCP4CR-SA3

**ROBO  
CYLINDER**

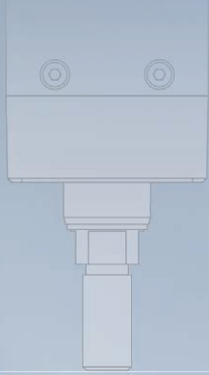

## RCP4 Series

Side-mounted Motor Type  
Series Added

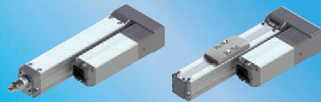

[www.intelligentactuator.com](http://www.intelligentactuator.com)

# RCP4 Series: SA3/RA3 Type with 32mm Actuator Width Now Has a Side-mounted Type



## RCP4 Series

Series	Specification	Style	Type	External View	Actuator Width	Stroke (mm)	Ballscrew Lead (mm)	Maximum Speed (mm/s)	Maximum Payload (kg)			
									Horizontal	Vertical		
RCP4	Motor Straight (Coupled)	Slider Type	SA3C			25~300	6	420	3	1.5		
							32mm	4	280	5	2.5	
								2	140	8	3.5	
			SA5C			50~800	20	1,440	6.5	1		
							12	900	9	2.5		
							6	450	18	6		
		SA6C			50~800	3	225	20	12			
						20	1,440	10	1			
						12	900	15	2.5			
		SA7C			50~800	6	450	25	6			
						3	225	25	12			
						24	1,200	20	3			
	Rod Type (Radial Cylinder)	Rod Type (Radial Cylinder)	RA3C			25~300	16	1,120	6	1.5		
							32mm	10	700	12	2.5	
							5	350	24	5		
			RA5C			50~400	2.5	175	36	10		
							20	800	6	1.5		
							12	700	25	4		
		RA6C			50~500	6	450	40	10			
						3	225	60	20			
						24	800	20	3			
		Side-mounted Motor	Slider Type	NEW SA3R			25~300	16	1,120	5	1	
								32mm	10	700	12	2.5
								5	350	24	5	
SA5R					50~800	2.5	175	36	10			
						20	800	6	1.5			
						12	700	25	4			
SA6R				50~800	6	450	40	10				
					3	225	60	20				
					24	800	20	3				
SA7R				50~800	16	1,000	20	3				
					16	840	40	8				
					8	490	45	16				
Rod Type (Radial Cylinder)	NEW RA3R			25~300	4	210	80	28				
					32mm	16	1,120	5	1			
					10	700	12	2.5				
	RA5R			50~400	5	350	24	5				
					2.5	175	36	10				
					20	800	6	1.5				
RA6R			50~500	12	700	25	4					
				6	450	40	10					
				3	225	60	20					
RCP4CR	Cleanroom	Slider Type	SA3C			25~300	24	800	20	3		
							16	560	50	8		
							8	420	60	18		
			SA5C			50~800	4	175	80	28		
							32mm	6	420	60	18	
								4	210	80	28	
SA6C			50~800	6	420	60	18					
				58mm	4	175	80	28				
					6	420	60	18				
SA7C			50~800	8	490	45	16					
				73mm	8	490	45	16				
					4	245	45	25				

●The horizontal payload of the Rod Type described above is that when an external guide is used.

## RCP5 Series

With Battery-less Absolute Encoder Installed as a Standard

Series	Specification	Style	Type	External View	Actuator Width	Stroke (mm)	Ballscrew Lead (mm)	Maximum Speed (mm/s)	Maximum Payload (kg)	
									Horizontal	Vertical
RCP5	Motor Straight (Coupled)	Slider Type	SA4C			50~800	16	1,260	4	1
							10	785	10	2.25
							5	390	12	4.5
							2.5	195	12	9
			20	1,440<1,280>	10	1				
			12	900	15	2.5				
			6	450	25	6				
			3	225	25	16				
			24	1,200	20	3				
		16	980<840>	40	8					
		8	490	45	16					
		4	245<210>	45	25					
		16	1,120<840>	6	1.5					
		10	700	15	2.5					
	5	350	28	5						
	2.5	175	40	10						
	20	800	6	1.5						
	12	700	25	4						
	6	450	40	10						
	3	225	60	20						
	24	800<600>	20	3						
	16	700<560>	50	8						
	8	420	60	18						
	4	210	80	28						
	20	600<450>	30	5						
	10	300<250>	60	40						
	5	150	100	70						
	10	250<167>	80	80						
5	125	150	100							
2.5	63	300	150							
16	1,260	4	1							
10	785	10	2.25							
5	390	12	4.5							
2.5	195	12	9							
20	1,280	10	1							
12	900<800>	15	2.5							
6	450	25	6							
3	225	25	12							
24	1,000	20	3							
16	840<700>	40	8							
8	490	45	16							
4	210	45	25							
16	840	5	1							
10	610	12	2.5							
5	350	25	5							
2.5	175	40	10							
20	800	6	1.5							
12	700	25	4							
6	450	40	10							
3	225	60	20							
24	800<600>	20	3							
16	560	50	8							
8	420<350>	60	18							
4	175	80	28							
20	400	30	5							
10	200	60	40							
5	100	100	70							
10	200<140>	80	80							
5	100	150	100							
2.5	50	300	150							

●The values in <> apply when the actuator is used vertically. ●Please refer to the individual catalog for the details of RCP5 Series.

# RCP4-SA3C

ROBO Cylinder, Slider Type, Motor Unit Coupled,  
Actuator Width 32mm, Pulse Motor 24V

Model Specification Items	<b>RCP4</b> — <b>SA3C</b> — <b>I</b> — <b>28P</b> — <input type="checkbox"/> — <input type="checkbox"/> — <b>P3</b> — <input type="checkbox"/> — <input type="checkbox"/>							
Series	Type	Encoder type	Motor type	Lead	Stroke	Applicable controllers	Cable length	Options
		I: Incremental specification	28P: Pulse motor Size 28□	6: 6mm 4: 4mm 2: 2mm	25: 25mm 300: 300mm (Every 25mm)	P3: PCON-CA MSEP MSEL	N: None P: 1m S: 3m M: 5m X□: Specified length R□: Robot cable	Refer to the option list below.

\*Controller is not included.  
\*Please refer to our ROBO Cylinder General Catalog for the contents of the model specification items.  
\*The simple absolute encoder is also considered type "I"

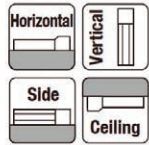

\* Depending on the model, there may be some limitations to using the vertical, side, and ceiling mount positions. Please contact us for more information.



- (1) The actuator specifications displays the payload's maximum value, but it will vary depending on the acceleration. Please refer to "The Tables for Payload by Speed and Acceleration" on P. 13.
- (2) Please refer to "Correlation Diagrams Between Push Force and Current Limit" on P. 14 for push-motion operation.

## Correlation Diagrams of Speed and Payload

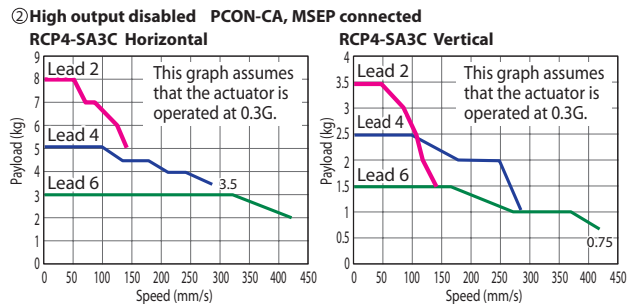
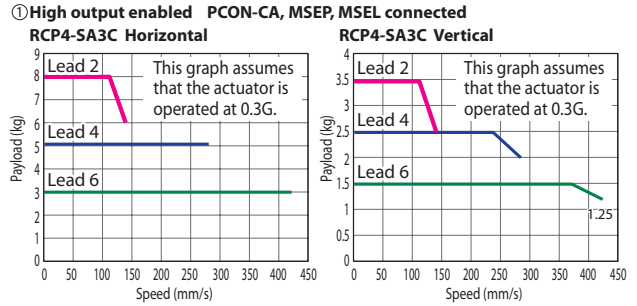

## Actuator Specifications

### Lead and Payload

Model Number	Lead (mm)	Maximum Payload		Stroke (mm)
		Horizontal (kg)	Vertical (kg)	
RCP4-SA3C-I-28P-6-①-P3-②-③	6	3	1.5	25 ~ 300 (Every 25mm)
RCP4-SA3C-I-28P-4-①-P3-②-③	4	5	2.5	
RCP4-SA3C-I-28P-2-①-P3-②-③	2	8	3.5	

Legend: ① Stroke ② Cable length ③ Options

### Stroke and Max. Speed (Unit: mm/s)

Lead (mm)	High-output Setting	25 ~ 300 (Every 25mm)
6	Enabled	420
	Disabled	
4	Enabled	280
	Disabled	
2	Enabled	140
	Disabled	

### ① Stroke

Stroke (mm)	Standard Price	Stroke (mm)	Standard Price
25	—	175	—
50	—	200	—
75	—	225	—
100	—	250	—
125	—	275	—
150	—	300	—

### ② Cable Length

Type	Cable Code	Standard Price
Standard Type	P (1m)	—
	S (3m)	—
	M (5m)	—
Specified Length	X06 (6m) ~ X10 (10m)	—
	X11 (11m) ~ X15 (15m)	—
	X16 (16m) ~ X20 (20m)	—
	R01 (1m) ~ R03 (3m)	—
Robot Cable	R04 (4m) ~ R05 (5m)	—
	R06 (6m) ~ R10 (10m)	—
	R11 (11m) ~ R15 (15m)	—
	R16 (16m) ~ R20 (20m)	—
	R16 (16m) ~ R20 (20m)	—

\* For a maintenance cable, please see the back cover.

### ③ Options \* Please check the Options reference pages to confirm each option.

Name	Option Code	Reference Page	Standard Price
Brake	B	Please refer to our ROBO Cylinder General Catalog.	—
Home-position Check Sensor (On Left)	HSL		—
Home-position Check Sensor (On Right)	HSR		—
Non-motor End Specification	NM		—
Slider Roller Specification	SR		—

\* For the home-position check sensor, there are 2 types; HSR (sensor attached on the right) and HSL (sensor attached on the left). Please see the following page for details.

## Actuator Specifications

Item	Description
Drive System	Ballscrew $\varnothing$ 6mm rolled C10
Positioning Repeatability	$\pm$ 0.02mm
Lost Motion	0.1mm or less
Base	Material: Aluminum with white alumite treatment
Dynamic Allowable Moment (*1)	Ma: 3.82N·m, Mb: 5.45N·m, Mc: 6.10N·m
Static Allowable Moment	Ma: 6.30N·m, Mb: 8.90N·m, Mc: 10.0N·m
Ambient Operating Temperature, Humidity	0 ~ 40°C, 85% RH or less (Non-condensing)

Reference for overhang load length of all 3 directions (Ma, Mb, and Mc): 100mm or less

(\*1) This assumes a standard life of 5,000km. The operational life will vary depending on operation and installation conditions.

\* Please refer to our ROBO Cylinder General Catalog for details on operational life, allowable moment direction, and overhang load length.

## Dimensions

CAD drawings can be downloaded from our website. [www.intelligentactuator.com](http://www.intelligentactuator.com)



- \*1 On the 25mm stroke type, there are six counterbored mounting holes on the bottom of the base, but the two counterbored mounting holes in the middle are not available to be used.
- \*2 When the slider is returning to its home position, please be careful of interference from surrounding objects, as it will travel until it reaches the ME.  
ME : Mechanical end  
SE : Stroke end
- \*3 Please see P. 12 for slider roller specification (SR).

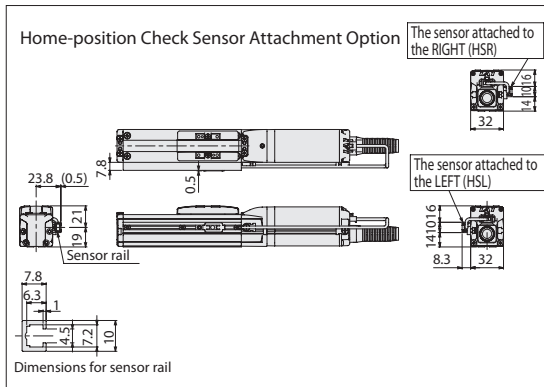
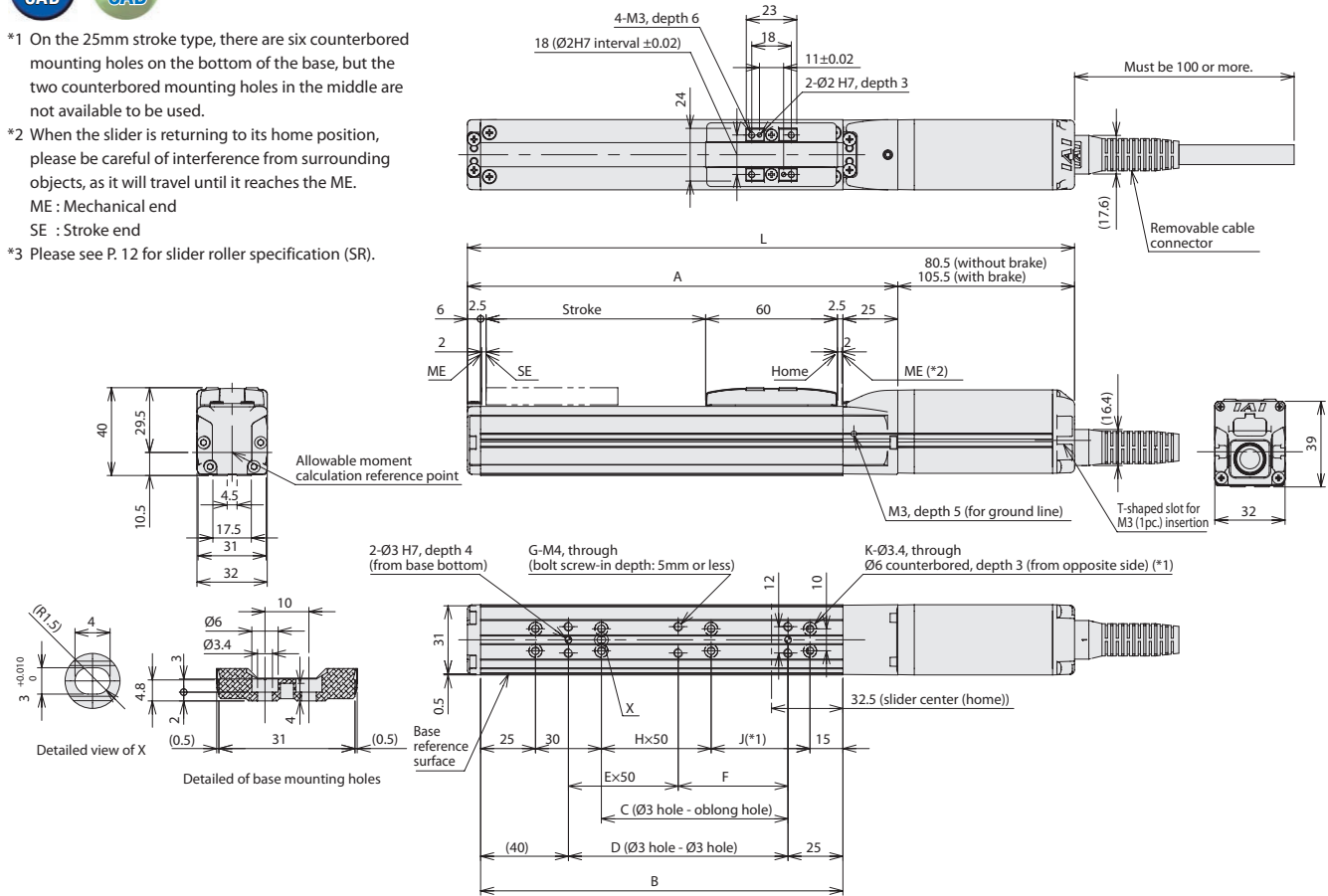

### Dimensions and Mass by Stroke

Stroke	25	50	75	100	125	150	175	200	225	250	275	300	
L	Without Brake	201.5	226.5	251.5	276.5	301.5	326.5	351.5	376.5	401.5	426.5	451.5	476.5
	With Brake	226.5	251.5	276.5	301.5	326.5	351.5	376.5	401.5	426.5	451.5	476.5	501.5
A	121	146	171	196	221	246	271	296	321	346	371	396	
B	90	115	140	165	190	215	240	265	290	315	340	365	
C	10	35	60	85	110	135	160	185	210	235	260	285	
D	25	50	75	100	125	150	175	200	225	250	275	300	
E	0	0	0	1	1	2	2	3	3	4	4	5	
F	25	50	75	50	75	50	75	50	75	50	75	50	
G	4	4	4	6	6	8	8	10	10	12	12	14	
H	0	0	0	1	1	2	2	3	3	4	4	5	
J	(20)	45	70	45	70	45	70	45	70	45	70	45	
K	(6)	6	6	8	8	10	10	12	12	14	14	16	
Mass (kg)	Without Brake	0.51	0.55	0.58	0.61	0.65	0.68	0.71	0.75	0.78	0.81	0.85	0.88
	With Brake	0.6	0.64	0.67	0.7	0.74	0.77	0.8	0.84	0.87	0.9	0.94	0.97

### Applicable Controllers

The RCP4 series actuators can be operated by the controllers indicated below. Please select the type depending to your intended use.

Name	External View	Model Number	Max. Number of Controlled Axes	Maximum Number of Positioning Points	Input Power	Standard Price	Reference Page
Positioner Type High-output Specification		PCON-CA-28P(V)-①-2-0	1	512 point	DC24V	-	Please see individual product catalogs for details
Pulse Train Type High-output Specification		PCON-CA-28PWAI-PL(V)-2-0		-		-	
Network Type High-output Specification		PCON-CA-28P(V)-③-0-0		768 point		-	
Solenoid Valve Multi-axis Type (PIO Specification)		MSEP-(V)-②-①-2-0	C: 8 (4 when high-output enabled)	3 point	-		
Solenoid Valve Multi-axis Type (Network Specification)		MSEP-(V)-②-③-0-0	LC: 6 (3 when high-output enabled)	256 point	-		
Program Control Multi-axis Type		MSEL-PC-1-28P(V)-①-2-4	4	30,000 point	Single-phase AC 100V ~230V	-	
Program Control Multi-axis Type w/Network Board		MSEL-PC-1-28P(V)-③-0-4					
Program Control Multi-axis Type Safety Category Compliant Specification		MSEL-PG-1-28P(V)-①-2-4					
Program Control Multi-axis Type Safety Category Compliant Spec. w/Network Board		MSEL-PG-1-28P(V)-③-0-4					

\*Above MSEL models are for single-axis specification \*① I/O type (NP/PN) \*② Number of axes \*③ Field network specification code  
 \*④ Encoder type: WAI=Incremental / SA=Simple absolute. However, WAI and SA cannot be used together for MSEL \*⑤ C (standard type) or LC (PLC function equipped type)  
 \*⑥ N (NPN specification)/P (PNP specification) code \*The high-output enabled operation is only available when the "High-output setting specification" is selected as an option for the MSEP-C/LC.



# RCP4-RA3C

ROBO Cylinder, Rod Type, Motor Unit Coupled,  
Actuator Width 32mm, Pulse Motor 24V

Model Specification Items	<b>RCP4 - RA3C</b>	<b>I</b>	<b>28P</b>	<b>Lead</b>	<b>Stroke</b>	<b>P3</b>	<b>Cable length</b>	<b>Options</b>
	Series	Type	Encoder type	Motor type		Applicable controllers		
			I: Incremental specification	28P: Pulse motor Size 28□	16: 16mm 10: 10mm 5: 5mm 2.5: 2.5mm	P3: PCON-CA MSEP MSEL	N: None P: 1m S: 3m M: 5m X□: Specified length R□: Robot cable	Refer to the option list below.

\*Controller is not included.  
\*Please refer to our ROBO Cylinder General Catalog for the contents of the model specification items.  
\*The Simple absolute encoder is also considered type "I"

## Radial Load Applicable

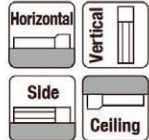

\* Depending on the model, there may be some limitations to using the vertical mount position. Please contact us for more information.

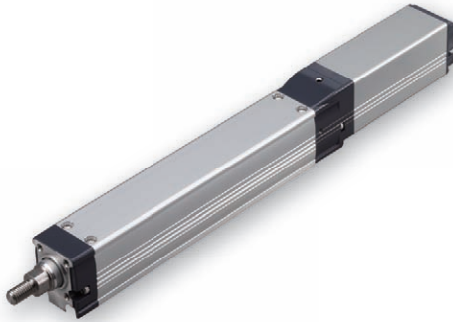

- (1) The actuator specifications displays the payload's maximum value, but it will vary depending on the acceleration. Please refer to "The Tables for Payload by Speed and Acceleration" on P. 13.
- (2) Please refer to "Correlation Diagrams Between Push Force and Current Limit" on P. 14 for push-motion operation.
- (3) The radial cylinder is equipped with a built-in guide. Please refer to the diagrams on back cover for allowable load mass.

## Correlation Diagrams of Speed and Payload

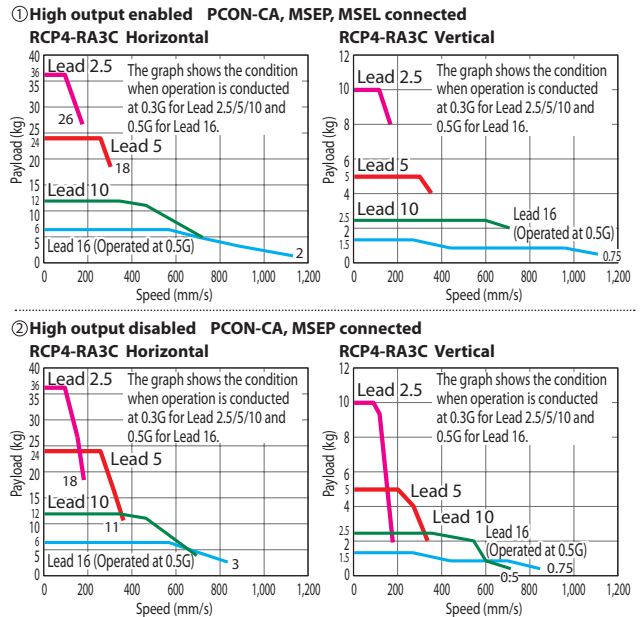

## Actuator Specifications

### Lead and Payload

Model Number	Lead (mm)	Maximum Payload		Maximum Push Force (N)	Stroke (mm)
		Horizontal (kg)	Vertical (kg)		
RCP4-RA3C-I-28P-16-①-P3-②-③	16	6	1.5	36	25 ~ 300 (Every 25mm)
RCP4-RA3C-I-28P-10-①-P3-②-③	10	12	2.5	57	
RCP4-RA3C-I-28P-5-①-P3-②-③	5	24	5	114	
RCP4-RA3C-I-28P-2.5-①-P3-②-③	2.5	36	10	229	

Legend: ① Stroke ② Cable length ③ Options \*Refer to P. 14 for the push-motion operation.

### Stroke and Max. Speed (Unit: mm/s)

Lead (mm)	High-output Setting	25 ~ 300 (Every 25mm)
16	Enabled	1,120
	Disabled	840
10	Enabled	700
	Disabled	350
5	Enabled	350
	Disabled	175
2.5	Enabled	175
	Disabled	175

### ① Stroke

Stroke (mm)	Standard Price	Stroke (mm)	Standard Price
25	—	175	—
50	—	200	—
75	—	225	—
100	—	250	—
125	—	275	—
150	—	300	—

### ② Cable Length

Type	Cable Code	Standard Price
Standard Type	P (1m)	—
	S (3m)	—
	M (5m)	—
Specified Length	X06 (6m) ~ X10 (10m)	—
	X11 (11m) ~ X15 (15m)	—
	X16 (16m) ~ X20 (20m)	—
Robot Cable	R01 (1m) ~ R03 (3m)	—
	R04 (4m) ~ R05 (5m)	—
	R06 (6m) ~ R10 (10m)	—
	R11 (11m) ~ R15 (15m)	—
	R16 (16m) ~ R20 (20m)	—
	R21 (21m) ~ R25 (25m)	—

\* For a maintenance cable, please see the back cover.

### ③ Options

\* Please check the Options reference pages to confirm each option.

Name	Option Code	Reference Page	Standard Price
Brake	B	Please refer to our ROBO Cylinder General Catalog.	—
Home-position Check Sensor (Top)	HS		—
Non-motor End Specification	NM		—

## Actuator Specifications

Item	Description
Drive System	Ballscrew Ø8mm rolled C10
Positioning Repeatability	±0.02mm
Lost Motion	0.1mm or less
Rod	Ø16mm Aluminum
Rod Non-rotation Precision(*1)	0 deg.
Allowable Load and Torque on Rod Tip	Refer to the table in the right page and the graph at the back cover of this catalog.
Rod Tip Overhang Distance	100mm or less
Ambient Operating Temperature, Humidity	0 ~ 40°C, 85% RH or less (Non-condensing)

(\*1) Accuracy of rod displacement in rotating direction when no load is received.

## Dimensions

CAD drawings can be downloaded from our website. [www.intelligentactuator.com](http://www.intelligentactuator.com)



- \*1 The two counterbored mounting holes (K) on the bottom of the base near the rod end are not available to use.
- \*2 When the rod is returning to its home position, please be careful of interference from surrounding objects, as it will travel until it reaches the ME. ME : Mechanical end SE : Stroke end
- \*3 The orientation of the bolt varies depending on the product.
- \*4 If the actuator is installed using the front housing, make sure that the actuator will not receive any external force.

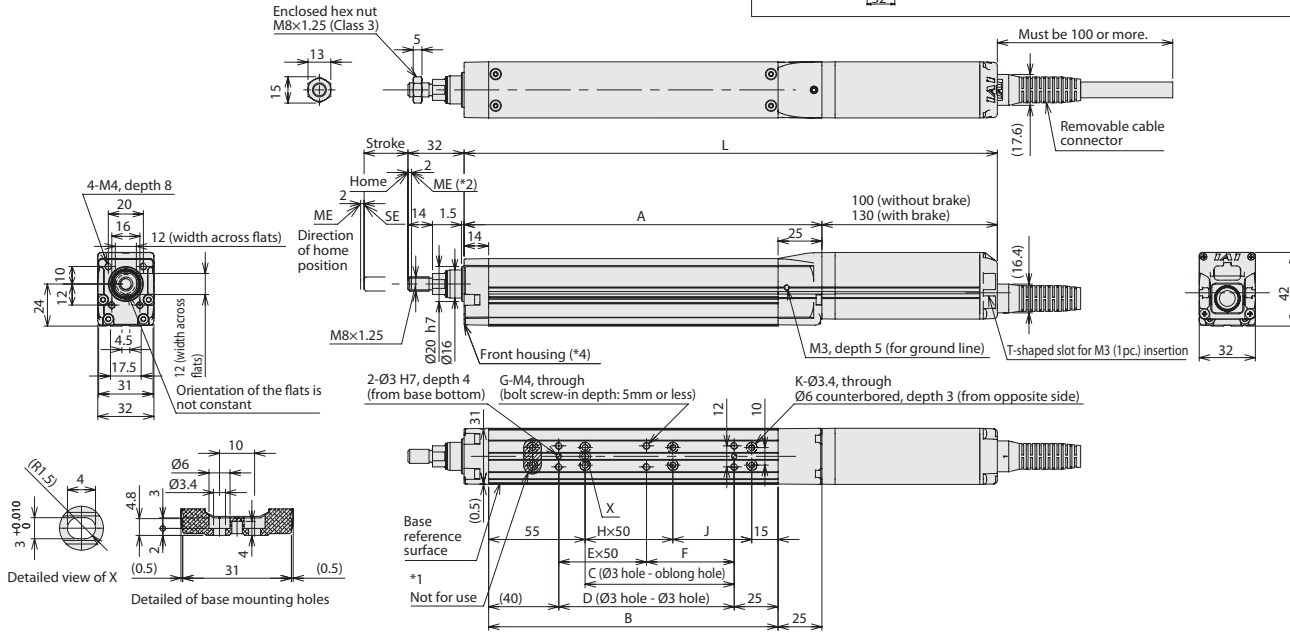
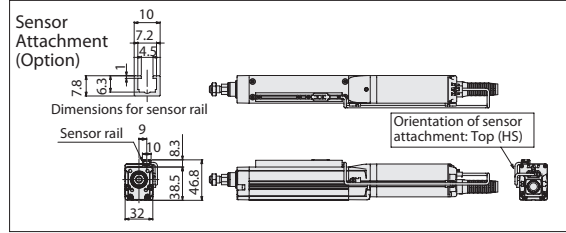

### RCP4-RA3C Rod Deflection (Reference)

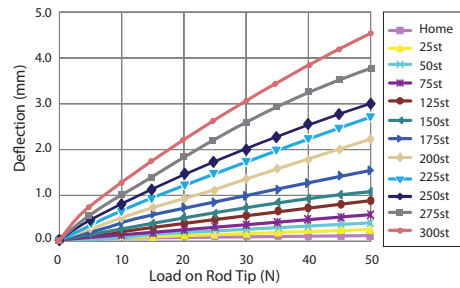

### Dimensions and Mass by Stroke

Stroke	Stroke												
	25	50	75	100	125	150	175	200	225	250	275	300	
L	Without Brake	229	254	279	304	329	354	379	404	429	454	479	504
	With Brake	259	284	309	334	359	384	409	434	459	484	509	534
A	129	154	179	204	229	254	279	304	329	354	379	404	
B	90	115	140	165	190	215	240	265	290	315	340	365	
C	10	35	60	85	110	135	160	185	210	235	260	285	
D	25	50	75	100	125	150	175	200	225	250	275	300	
E	0	0	0	1	1	2	2	3	3	4	4	5	
F	25	50	75	50	75	50	75	50	75	50	75	50	
G	4	4	4	6	6	8	8	10	10	12	12	14	
H	0	0	0	1	1	2	2	3	3	4	4	5	
J	20	45	70	45	70	45	70	45	70	45	70	45	
K	4	4	4	6	6	8	8	10	10	12	12	14	
Allowable Static Load on Rod Tip (N)	38.8	33.5	29.5	26.3	23.7	21.6	19.8	18.2	16.9	15.7	14.7	13.8	
Allowable Dynamic Load on Rod Tip (N)	19.4	16.6	14.2	12.2	10.7	9.5	8.5	7.7	7.0	6.4	5.8	5.4	
Allowable Static Torque on Rod Tip (N·m)	9.1	9.4	8.9	8.3	7.7	7.1	6.6	6.1	5.6	5.2	4.9	4.5	
Allowable Dynamic Torque on Rod Tip (N·m)	3.9	3.4	3.0	2.7	2.4	2.2	2.0	1.9	1.7	1.6	1.5	1.4	
Mass (kg)	Without Brake	0.59	0.64	0.69	0.73	0.78	0.83	0.88	0.93	0.98	1.02	1.07	1.12
	With Brake	0.68	0.73	0.78	0.82	0.87	0.92	0.97	1.02	1.07	1.11	1.16	1.21

### Applicable Controllers

The RCP4 series actuators can be operated by the controllers indicated below. Please select the type depending to your intended use.

Name	External View	Model Number	Max. Number of Controlled Axes	Maximum Number of Positioning Points	Input Power	Standard Price	Reference Page
Positioner Type High-output Specification		PCON-CA-28P(V)-①-2-0	1	512 point	DC24V	-	Please see individual product catalogs for details
Pulse Train Type High-output Specification		PCON-CA-28PWAI-PL(V)-②-0		-		-	
Network Type High-output Specification		PCON-CA-28P(V)-③-0-0		768 point		-	
Solenoid Valve Multi-axis Type (PIO Specification)		MSEP-(V)-④-①-2-0	C: 8 (4 when high-output enabled)	3 point	-		
Solenoid Valve Multi-axis Type (Network Specification)		MSEP-(V)-④-③-0-0	LC: 6 (3 when high-output enabled)	256 point			
Program Control Multi-axis Type		MSEL-PC-1-28P(V)-①-2-4	4	30,000 point	Single-phase AC 100V ~230V	-	
Program Control Multi-axis Type w/Network Board		MSEL-PC-1-28P(V)-③-0-4					
Program Control Multi-axis Type Safety Category Compliant Specification		MSEL-PG-1-28P(V)-①-2-4					
Program Control Multi-axis Type Safety Category Compliant Spec. w/Network Board		MSEL-PG-1-28P(V)-③-0-4					

\*Above MSEL models are for single-axis specification \*① I/O type (NP/PN) \*② Number of axes \*③ Field network specification code  
 \*④ Encoder type: WAI=Incremental / SA=Simple absolute. However, WAI and SA cannot be used together for MSEL \*⑤ C (standard type) or LC (PLC function equipped type)  
 \*⑥ N (NPN specification)/P (PNP specification) code \*The high-output enabled operation is only available when the "High-output setting specification" is selected as an option for the MSEP-C/LC.

# RCP4-SA3R

ROBO Cylinder, Slider Type, Side-mounted Motor Unit, Actuator Width 32mm, Pulse Motor 24V

Model Specification Items	<b>RCP4</b> — <b>SA3R</b> — <b>I</b> — <b>28P</b> — <input type="checkbox"/> — <input type="checkbox"/> — <b>P3</b> — <input type="checkbox"/> — <input type="checkbox"/>							
Series	Type	Encoder type	Motor type	Lead	Stroke	Applicable controllers	Cable length	Options
		I: Incremental specification	28P: Pulse motor Size 28□	6: 6mm 4: 4mm 2: 2mm	25: 25mm 300: 300mm (Every 25mm)	P3: PCON-CA MSEP MSEL	N: None P: 1m S: 3m M: 5m X□: Specified length R□: Robot cable	Refer to the option list below.

\*Controller is not included.  
\*Please refer to our ROBO Cylinder General Catalog for the contents of the model specification items.  
\*The Simple absolute encoder is also considered type "I"

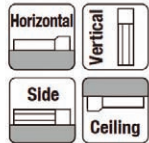

\* Depending on the model, there may be some limitations to using the vertical, side, and ceiling mount positions. Please contact us for more information.

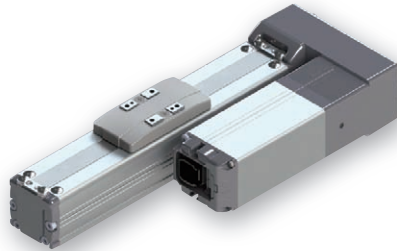

The figure above is the side-mounted motor specification (ML).

**POINT**  
Note on selection

(1) The actuator specifications displays the payload's maximum value, but it will vary depending on the acceleration. Please refer to "The Tables for Payload by Speed and Acceleration" on P. 13.

(2) Please refer to "Correlation Diagrams Between Push Force and Current Limit" on P. 14 for push-motion operation.

## Correlation Diagrams of Speed and Payload

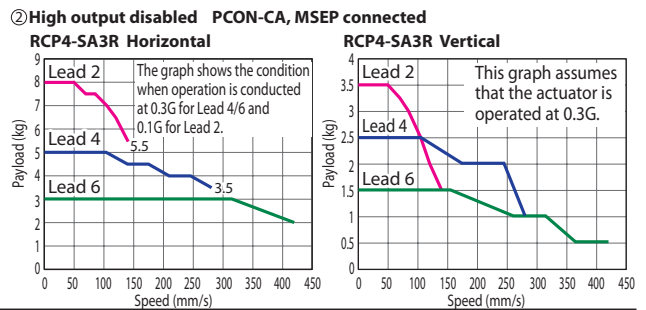
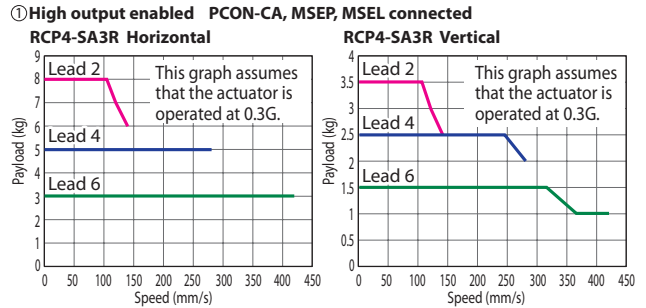

## Actuator Specifications

### Lead and Payload

Model Number	Lead (mm)	Maximum Payload		Stroke (mm)
		Horizontal (kg)	Vertical (kg)	
RCP4-SA3R-I-28P-6-①-P3-②-③	6	3	1.5	25 ~ 300 (Every 25mm)
RCP4-SA3R-I-28P-4-①-P3-②-③	4	5	2.5	
RCP4-SA3R-I-28P-2-①-P3-②-③	2	8	3.5	

Legend: ① Stroke ② Cable length ③ Options

### Stroke and Max. Speed (Unit: mm/s)

Lead (mm)	High-output Setting	25 ~ 300 (Every 25mm)
6	Enabled	420
	Disabled	
4	Enabled	280
	Disabled	
2	Enabled	140
	Disabled	

### ① Stroke

Stroke (mm)	Standard Price	Stroke (mm)	Standard Price
25	—	175	—
50	—	200	—
75	—	225	—
100	—	250	—
125	—	275	—
150	—	300	—

### ② Cable Length

Type	Cable Code	Standard Price
Standard Type	P (1m)	—
	S (3m)	—
	M (5m)	—
Specified Length	X06 (6m) ~ X10 (10m)	—
	X11 (11m) ~ X15 (15m)	—
	X16 (16m) ~ X20 (20m)	—
	R01 (1m) ~ R03 (3m)	—
Robot Cable	R04 (4m) ~ R05 (5m)	—
	R06 (6m) ~ R10 (10m)	—
	R11 (11m) ~ R15 (15m)	—
	R16 (16m) ~ R20 (20m)	—

\* For a maintenance cable, please see the back cover.

### ③ Options \* Please check the Options reference pages to confirm each option.

Name	Option Code	Reference Page	Standard Price
Brake	B	—	—
Motor Side-mounted to the Left	ML	Please refer to our ROBO Cylinder General Catalog.	—
Motor Side-mounted to the Right	MR		—
Home-position Check Sensor (On Left)(*1)	HSL		—
Home-position Check Sensor (On Right)(*1)	HSR		—
Non-motor End Specification	NM		—
Slider Roller Specification	SR		—
Back Attachment Plate	RP	→P. 8	—

(\*1) Select "HSR" when the motor mounted direction is ML and "HSL" when the motor mounted direction is MR.

### Actuator Specifications

Item	Description
Drive System	Ballscrew Ø6mm rolled C10
Positioning Repeatability	±0.02mm
Lost Motion	0.1mm or less
Base	Material: Aluminum with white alumite treatment
Dynamic Allowable Moment (*1)	Ma: 3.82N·m, Mb: 5.45N·m, Mc: 6.10N·m
Static Allowable Moment	Ma: 6.30N·m, Mb: 8.90N·m, Mc: 10.0N·m
Ambient Operating Temperature, Humidity	0 ~ 40°C, 85% RH or less (Non-condensing)

Reference for overhang load length of all 3 directions (Ma, Mb, and Mc): 100mm or less

(\*1) This assumes a standard life of 5,000km. The operational life will vary depending on operation and installation conditions.

\* Please refer to our ROBO Cylinder General Catalog for details on operational life, allowable moment direction, and overhang load length.



## Dimensions

CAD drawings can be downloaded from our website. [www.intelligentactuator.com](http://www.intelligentactuator.com)



- \*1 On the 25mm stroke type, there are six counterbored mounting holes on the bottom of the base, but the two counterbored mounting holes in the middle are not available to be used.
- \*2 When the slider is returning to its home position, please be careful of interference from surrounding objects, as it will travel until it reaches the ME.

ME : Mechanical end  
SE : Stroke end

M3, depth 5 (same on opposite side)  
For ground line

Detailed view of Y

Allowable moment calculation reference point

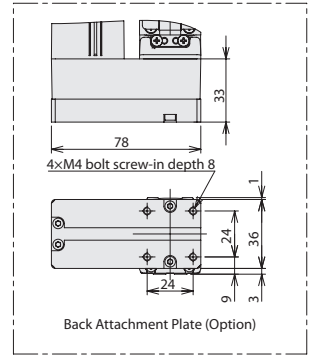
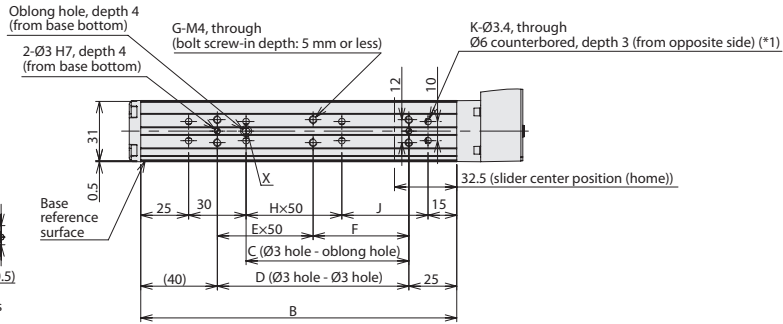
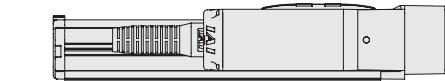
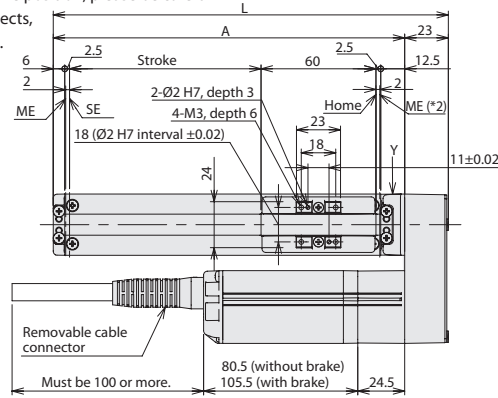
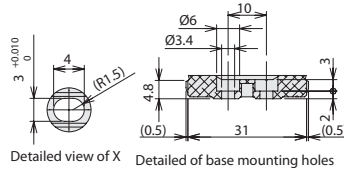
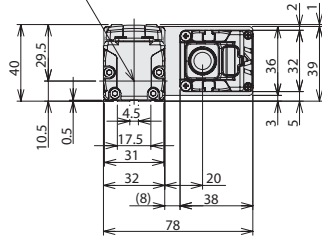

### Sensor Attachment (Option)

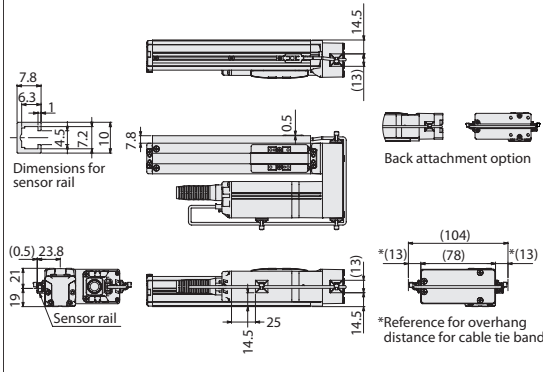

### Dimensions and Mass by Stroke

Stroke	25	50	75	100	125	150	175	200	225	250	275	300	
L	Standard	131.5	156.5	181.5	206.5	231.5	256.5	281.5	306.5	331.5	356.5	381.5	406.5
	Back Attachment Option	141.5	166.5	191.5	216.5	241.5	266.5	291.5	316.5	341.5	366.5	391.5	416.5
A	108.5	133.5	158.5	183.5	208.5	233.5	258.5	283.5	308.5	333.5	358.5	383.5	
B	90	115	140	165	190	215	240	265	290	315	340	365	
C	10	35	60	85	110	135	160	185	210	235	260	285	
D	25	50	75	100	125	150	175	200	225	250	275	300	
E	0	0	0	1	1	2	2	3	3	4	4	5	
F	25	50	75	50	75	50	75	50	75	50	75	50	
G	4	4	4	6	6	8	8	10	10	12	12	14	
H	0	0	0	1	1	2	2	3	3	4	4	5	
J	(20)	45	70	45	70	45	70	45	70	45	70	45	
K	(6)	6	6	8	8	10	10	12	12	14	14	16	
Mass (kg)	Without Brake	0.64	0.68	0.71	0.74	0.78	0.81	0.84	0.88	0.91	0.94	0.98	1.01
	With Brake	0.73	0.77	0.80	0.83	0.87	0.90	0.93	0.97	1.00	1.03	1.07	1.10

### Applicable Controllers

The RCP4 series actuators can be operated by the controllers indicated below. Please select the type depending to your intended use.

Name	External View	Model Number	Max. Number of Controlled Axes	Maximum Number of Positioning Points	Input Power	Standard Price	Reference Page
Positioner Type High-output Specification		PCON-CA-28P(V)-①-2-0	1	512 point	DC24V	-	Please see individual product catalogs for details
Pulse Train Type High-output Specification		PCON-CA-28PWAI-PL(V)-②-0		-			
Network Type High-output Specification		PCON-CA-28P(V)-③-0-0		768 point			
Solenoid Valve Multi-axis Type (PIO Specification)		MSEP-(V)-④-①-2-0	C: 8 (4 when high-output enabled) LC: 6 (3 when high-output enabled)	3 point	Single-phase AC 100V ~230V	-	
Solenoid Valve Multi-axis Type (Network Specification)		MSEP-(V)-④-③-0-0		256 point			
Program Control Multi-axis Type		MSEL-PC-1-28P(V)-①-2-4	4	30,000 point	Single-phase AC 100V ~230V	-	
Program Control Multi-axis Type w/Network Board		MSEL-PC-1-28P(V)-③-0-4					
Program Control Multi-axis Type Safety Category Compliant Specification		MSEL-PG-1-28P(V)-①-2-4					
Program Control Multi-axis Type Safety Category Compliant Spec. w/Network Board		MSEL-PG-1-28P(V)-③-0-4					

\*Above MSEL models are for single-axis specification \*① I/O type (NP/PN) \*② Number of axes \*③ Field network specification code  
 \*④ Encoder type: WAI=Incremental / SA=Simple absolute. However, WAI and SA cannot be used together for MSEL \*⑤ C (standard type) or LC (PLC function equipped type)  
 \*⑥ N (NPN specification)/P (PNP specification) code \*The high-output enabled operation is only available when the "High-output setting specification" is selected as an option for the MSEP-C/LC.

# RCP4-RA3R

ROBO Cylinder, Rod Type, Side-mounted Motor Unit,  
Actuator Width 32mm, Pulse Motor 24V

Model Specification Items	<b>RCP4</b> — <b>RA3R</b> — <b>I</b> — <b>28P</b>	<b>Lead</b>	<b>Stroke</b>	<b>P3</b>	<b>Cable length</b>	<b>Options</b>
	Series — Type — Encoder type — Motor type	Lead	Stroke	Applicable controllers	Cable length	Options
	I: Incremental specification *The Simple absolute encoder is also considered type "I"	28P: Pulse motor Size 28□	16: 16mm 10: 10mm 5: 5mm 2.5: 2.5mm	P3: PCON-CA MSEP MSEL	N: None P: 1m S: 3m M: 5m X□□: Specified length R□□: Robot cable	Refer to the option list below.

\*Controller is not included.  
\*Please refer to our ROBO Cylinder General Catalog for the contents of the model specification items.

## Radial Load Applicable

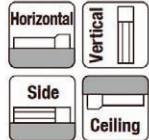

\* Depending on the model, there may be some limitations to using the vertical mount position. Please contact us for more information.

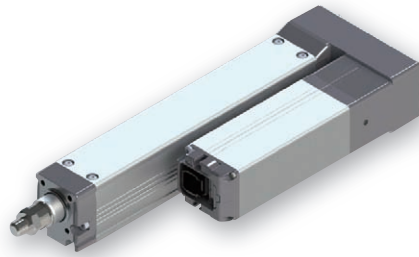

The figure above is the side-mounted motor specification (ML).

- POINT**  
Note on selection
- (1) The actuator specifications displays the payload's maximum value, but it will vary depending on the acceleration. Please refer to "The Tables for Payload by Speed and Acceleration" on P. 13.
  - (2) Please refer to "Correlation Diagrams Between Push Force and Current Limit" on P. 14 for push-motion operation.
  - (3) The radial cylinder is equipped with a built-in guide. Please refer to the diagrams on back cover for allowable load mass.

## Correlation Diagrams of Speed and Payload

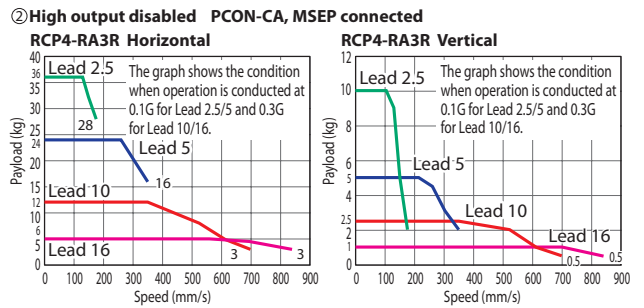
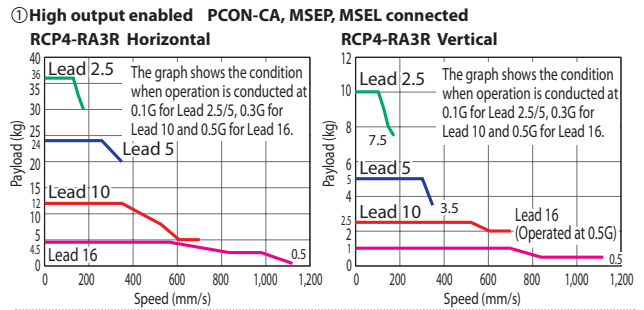

## Actuator Specifications

### Lead and Payload

Model Number	Lead (mm)	Maximum Payload		Maximum Push Force (N)	Stroke (mm)
		Horizontal (kg)	Vertical (kg)		
RCP4-RA3R-I-28P-16-①-P3-②-③	16	5	1	36	25 ~ 300 (Every 25mm)
RCP4-RA3R-I-28P-10-①-P3-②-③	10	12	2.5	57	
RCP4-RA3R-I-28P-5-①-P3-②-③	5	24	5	114	
RCP4-RA3R-I-28P-2.5-①-P3-②-③	2.5	36	10	229	

Legend: ① Stroke ② Cable length ③ Options

### Stroke and Max. Speed (Unit: mm/s)

Lead (mm)	High-output Setting	25 ~ 300 (Every 25mm)
16	Enabled	1,120
	Disabled	840
10	Enabled	700
	Disabled	350
5	Enabled	350
	Disabled	175
2.5	Enabled	175
	Disabled	87.5

### ① Stroke

Stroke (mm)	Standard Price	Stroke (mm)	Standard Price
25	—	175	—
50	—	200	—
75	—	225	—
100	—	250	—
125	—	275	—
150	—	300	—

### ② Cable Length

Type	Cable Code	Standard Price
Standard Type	P (1m)	—
	S (3m)	—
	M (5m)	—
Specified Length	X06 (6m) ~ X10 (10m)	—
	X11 (11m) ~ X15 (15m)	—
	X16 (16m) ~ X20 (20m)	—
Robot Cable	R01 (1m) ~ R03 (3m)	—
	R04 (4m) ~ R05 (5m)	—
	R06 (6m) ~ R10 (10m)	—
	R11 (11m) ~ R15 (15m)	—
	R16 (16m) ~ R20 (20m)	—
	R21 (21m) ~ R25 (25m)	—

\* For a maintenance cable, please see the back cover.

### ③ Options

\* Please check the Options reference pages to confirm each option.

Name	Option Code	Reference Page	Standard Price
Brake	B	—	—
Motor Side-mounted to the Left	ML	Please refer to our ROBO Cylinder General Catalog.	—
Motor Side-mounted to the Right	MR		—
Home-position Check Sensor	HS		—
Non-motor End Specification	NM		—
Back Attachment Plate	RP		—

## Actuator Specifications

Item	Description
Drive System	Ballscrew Ø8mm rolled C10
Positioning Repeatability	±0.02mm
Lost Motion	0.1mm or less
Rod	Ø16mm Aluminum
Rod Non-rotation Precision(*1)	0 deg.
Allowable Load and Torque on Rod Tip	Refer to the table in the right page and the graph at the back cover of this catalog.
Rod Tip Overhang Distance	100mm or less
Ambient Operating Temperature, Humidity	0 ~ 40°C, 85% RH or less (Non-condensing)

(\*1) Accuracy of rod displacement in rotating direction when no load is received.

## Dimensions

CAD drawings can be downloaded from our website. [www.intelligentactuator.com](http://www.intelligentactuator.com)

2D CAD

3D CAD

- \*1 The two counterbored mounting holes (K) on the bottom of the base near the rod end are not available to use.
- \*2 When the rod is returning to its home position, please be careful of interference from surrounding objects, as it will travel until it reaches the ME.  
ME : Mechanical end  
SE : Stroke end
- \*3 The orientation of the bolt varies depending on the product.
- \*4 If the actuator is installed using the front housing, make sure that the actuator will not receive any external force.

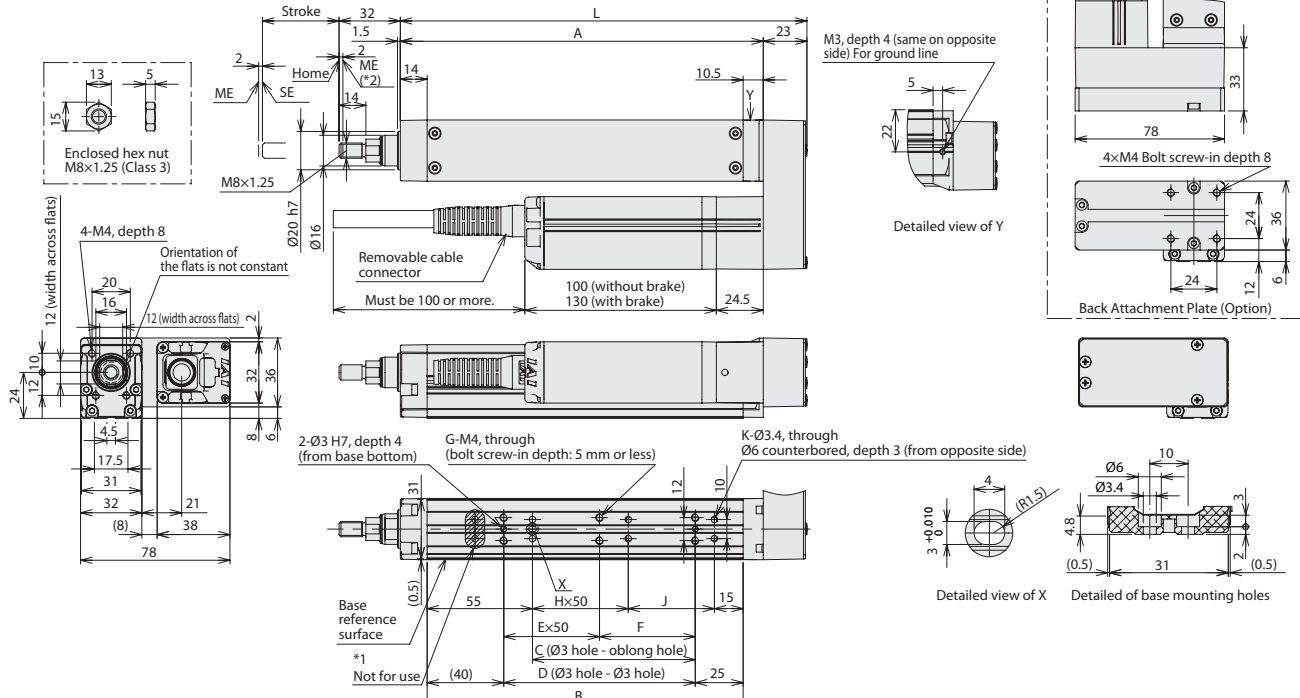
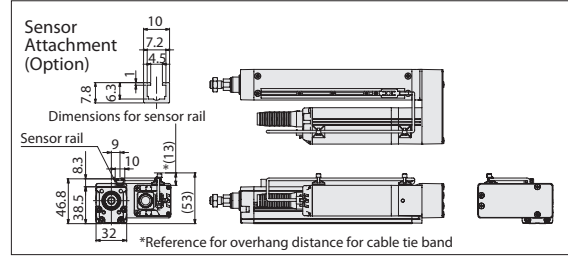

### RCP4-RA3R Rod Deflection (Reference)

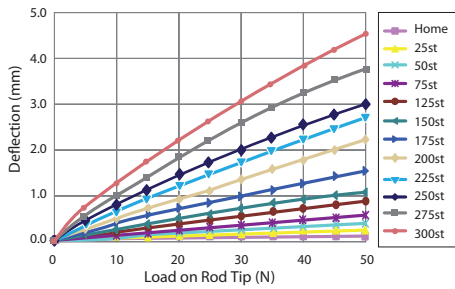

### Dimensions and Mass by Stroke

Stroke	Dimensions and Mass by Stroke												
	25	50	75	100	125	150	175	200	225	250	275	300	
L	Standard	137.5	162.5	187.5	212.5	237.5	262.5	287.5	312.5	337.5	362.5	387.5	412.5
	Back Attachment Option	147.5	172.5	197.5	222.5	247.5	272.5	297.5	322.5	347.5	372.5	397.5	422.5
A	114.5	139.5	164.5	189.5	214.5	239.5	264.5	289.5	314.5	339.5	364.5	389.5	
B	90	115	140	165	190	215	240	265	290	315	340	365	
C	10	35	60	85	110	135	160	185	210	235	260	285	
D	25	50	75	100	125	150	175	200	225	250	275	300	
E	0	0	0	1	1	2	2	3	3	4	4	5	
F	25	50	75	50	75	50	75	50	75	50	75	50	
G	4	4	4	6	6	8	8	10	10	12	12	14	
H	0	0	0	1	1	2	2	3	3	4	4	5	
J	20	45	70	45	70	45	70	45	70	45	70	45	
K	4	4	4	6	6	8	8	10	10	12	12	14	
Allowable Static Load on Rod Tip (N)	38.8	33.5	29.5	26.3	23.7	21.6	19.8	18.2	16.9	15.7	14.7	13.8	
Allowable Dynamic Load on Rod Tip (N)	19.4	16.6	14.2	12.2	10.7	9.5	8.5	7.7	7.0	6.4	5.8	5.4	
Load Offset 0mm	9.1	9.4	8.9	8.3	7.7	7.1	6.6	6.1	5.6	5.2	4.9	4.5	
Load Offset 100mm	3.9	3.4	3.0	2.7	2.4	2.2	2.0	1.9	1.7	1.6	1.5	1.4	
Allowable Static Torque on Rod Tip (N·m)	0.9	0.9	0.9	0.8	0.8	0.7	0.7	0.6	0.6	0.5	0.5	0.5	
Mass (kg)	Without Brake	0.71	0.76	0.81	0.85	0.90	0.95	1.00	1.05	1.10	1.14	1.19	1.24
	With Brake	0.80	0.85	0.90	0.94	0.99	1.04	1.09	1.14	1.19	1.23	1.28	1.33

### Applicable Controllers

The RCP4 series actuators can be operated by the controllers indicated below. Please select the type depending to your intended use.

Name	External View	Model Number	Max. Number of Controlled Axes	Maximum Number of Positioning Points	Input Power	Standard Price	Reference Page
Positioner Type High-output Specification		PCON-CA-28P(V)-①-2-0	1	512 point	DC24V	-	Please see individual product catalogs for details
Pulse Train Type High-output Specification		PCON-CA-28PWAI-PL(V)-②-0		-		-	
Network Type High-output Specification		PCON-CA-28P(V)-③-0-0		768 point		-	
Solenoid Valve Multi-axis Type (PIO Specification)		MSEP-(V)-④-①-2-0	C: 8 (4 when high-output enabled)	3 point	-	-	
Solenoid Valve Multi-axis Type (Network Specification)		MSEP-(V)-④-③-0-0	LC: 6 (3 when high-output enabled)	256 point			
Program Control Multi-axis Type		MSEL-PC-1-28P(V)-①-2-4	4	30,000 point	Single-phase AC 100V ~230V	-	
Program Control Multi-axis Type w/Network Board		MSEL-PC-1-28P(V)-③-0-4					
Program Control Multi-axis Type Safety Category Compliant Specification		MSEL-PG-1-28P(V)-①-2-4					
Program Control Multi-axis Type Safety Category Compliant Spec. w/Network Board		MSEL-PG-1-28P(V)-③-0-4					

\*Above MSEL models are for single-axis specification \*① I/O type (NP/PN) \*② Number of axes \*③ Field network specification code  
 \*④ Encoder type: WAI=Incremental / SA=Simple absolute. However, WAI and SA cannot be used together for MSEL \*⑤ C (standard type) or LC (PLC function equipped type)  
 \*⑥ N (NPN specification)/P (PNP specification) code \*The high-output enabled operation is only available when the "High-output setting specification" is selected as an option for the MSEP-C/LC.

# RCP4CR-SA3C Cleanroom Type ROBO Cylinder, Slider Type, Motor Unit Coupled, Actuator Width 32mm, Pulse Motor 24V

Model Specification Items	<b>RCP4CR</b> — <b>SA3C</b> — <b>I</b> — <b>28P</b> — <input type="checkbox"/> — <input type="checkbox"/> — <b>P3</b> — <input type="checkbox"/> — <input type="checkbox"/>
Series	Encoder type — Motor type — Lead — Stroke — Applicable controllers — Cable length — Options
	I: Incremental specification 28P: Pulse motor Size 28□ 6: 6mm 4: 4mm 2: 2mm 25: 25mm 300: 300mm (Every 25mm) P3: PCON-CA MSEP MSEL N: None P: 1m S: 3m M: 5m X□: Specified length R□: Robot cable Refer to the option list below.

\*Controller is not included.  
\*Please refer to our ROBO Cylinder General Catalog for the contents of the model specification items.  
\*The simple absolute encoder is also considered type "I"

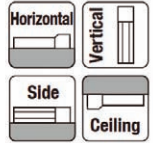

\* Depending on the model, there may be some limitations to using the vertical, side, and ceiling mount positions. Please contact us for more information.



- (1) The actuator specifications displays the payload's maximum value, but it will vary depending on the acceleration. Please refer to "The Tables for Payload by Speed and Acceleration" on P. 13.
- (2) Please refer to "Correlation Diagrams Between Push Force and Current Limit" on P. 14 for push-motion operation.

## Correlation Diagrams of Speed and Payload

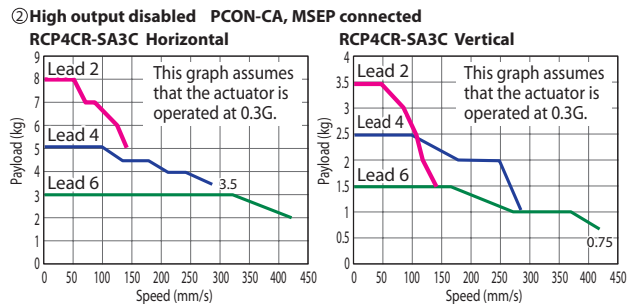
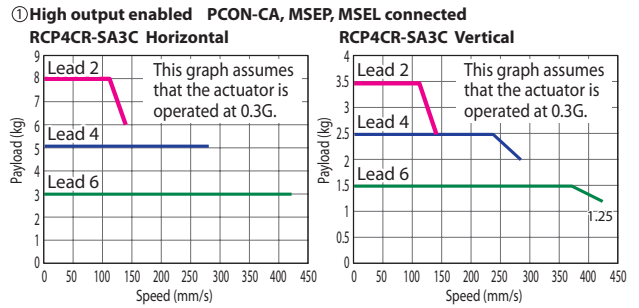

## Actuator Specifications

### Lead and Payload

Model Number	Lead (mm)	Maximum Payload		Stroke (mm)
		Horizontal (kg)	Vertical (kg)	
RCP4CR-SA3C-I-28P-6-①-P3-②-③	6	3	1.5	25 ~ 300 (Every 25mm)
RCP4CR-SA3C-I-28P-4-①-P3-②-③	4	5	2.5	
RCP4CR-SA3C-I-28P-2-①-P3-②-③	2	8	3.5	

Legend: ① Stroke ② Cable length ③ Options

### Stroke, Max. Speed and Vacuum Volume (Unit: mm/s)

Lead (mm)	High-output Setting	25 ~ 300 (Every 25mm)	Vacuum Volume (Nℓ/mm)
6	Enabled	420	20
	Disabled		
4	Enabled	280	15
	Disabled		
2	Enabled	140	10
	Disabled		

### ① Stroke

Stroke (mm)	Standard Price	Stroke (mm)	Standard Price
25	—	175	—
50	—	200	—
75	—	225	—
100	—	250	—
125	—	275	—
150	—	300	—

### ② Cable Length

Type	Cable Code	Standard Price
Standard Type	P (1m)	—
	S (3m)	—
	M (5m)	—
Specified Length	X06 (6m) ~ X10 (10m)	—
	X11 (11m) ~ X15 (15m)	—
	X16 (16m) ~ X20 (20m)	—
	R01 (1m) ~ R03 (3m)	—
Robot Cable	R04 (4m) ~ R05 (5m)	—
	R06 (6m) ~ R10 (10m)	—
	R11 (11m) ~ R15 (15m)	—
	R16 (16m) ~ R20 (20m)	—
	R16 (16m) ~ R20 (20m)	—

\* For a maintenance cable, please see the back cover.

### ③ Options

\* Please check the Options reference pages to confirm each option.

Name	Option Code	Reference Page	Standard Price
Brake	B	Please refer to our ROBO Cylinder General Catalog.	—
Home-position Check Sensor (On Left)	HSL		—
Home-position Check Sensor (On Right)	HSR		—
Non-motor End Specification	NM		—
Vacuum Joint Opposite Position	VR		—

\* For the home-position check sensor, there are 2 types; HSR (sensor attached on the right) and HSL (sensor attached on the left). Please see the following page for details.

## Actuator Specifications

Item	Description
Drive System	Ballscrew Ø6mm rolled C10
Positioning Repeatability	±0.02mm
Lost Motion	0.1mm or less
Base	Material: Aluminum with white alumite treatment
Guide	Linear guide
Dynamic Allowable Moment (*1)	Ma: 3.82N·m, Mb: 5.45N·m, Mc: 6.10N·m
Static Allowable Moment	Ma: 6.30N·m, Mb: 8.90N·m, Mc: 10.0N·m
Grease	Low particle-emission (urea based) grease used (on both ball screw and guide)
Cleanliness Class	Class 10 (Fed. Std. 209D), Equiv. to Class 2.5 (ISO 14644-1)
Ambient Operating Temperature, Humidity	0 ~ 40°C, 85% RH or less (Non-condensing)

Reference for overhang load length of all 3 directions (Ma, Mb, and Mc): 100mm or less

(\*1) This assumes a standard life of 5,000km. The operational life will vary depending on operation and installation conditions.

\* Please refer to our ROBO Cylinder General Catalog for details on operational life, allowable moment direction, and overhang load length.

## Dimensions

CAD drawings can be downloaded from our website. [www.intelligentactuator.com](http://www.intelligentactuator.com)



- \*1 On the 25mm stroke type, there are six counterbored mounting holes on the bottom of the base, but the two counterbored mounting holes in the middle are not available to be used.
- \*2 When the slider is returning to its home position, please be careful of interference from surrounding objects, as it will travel until it reaches the ME.  
ME : Mechanical end  
SE : Stroke end
- \*3 For standard type RCP4-SA3C slider roller specification (SR), there is no pipe joint.

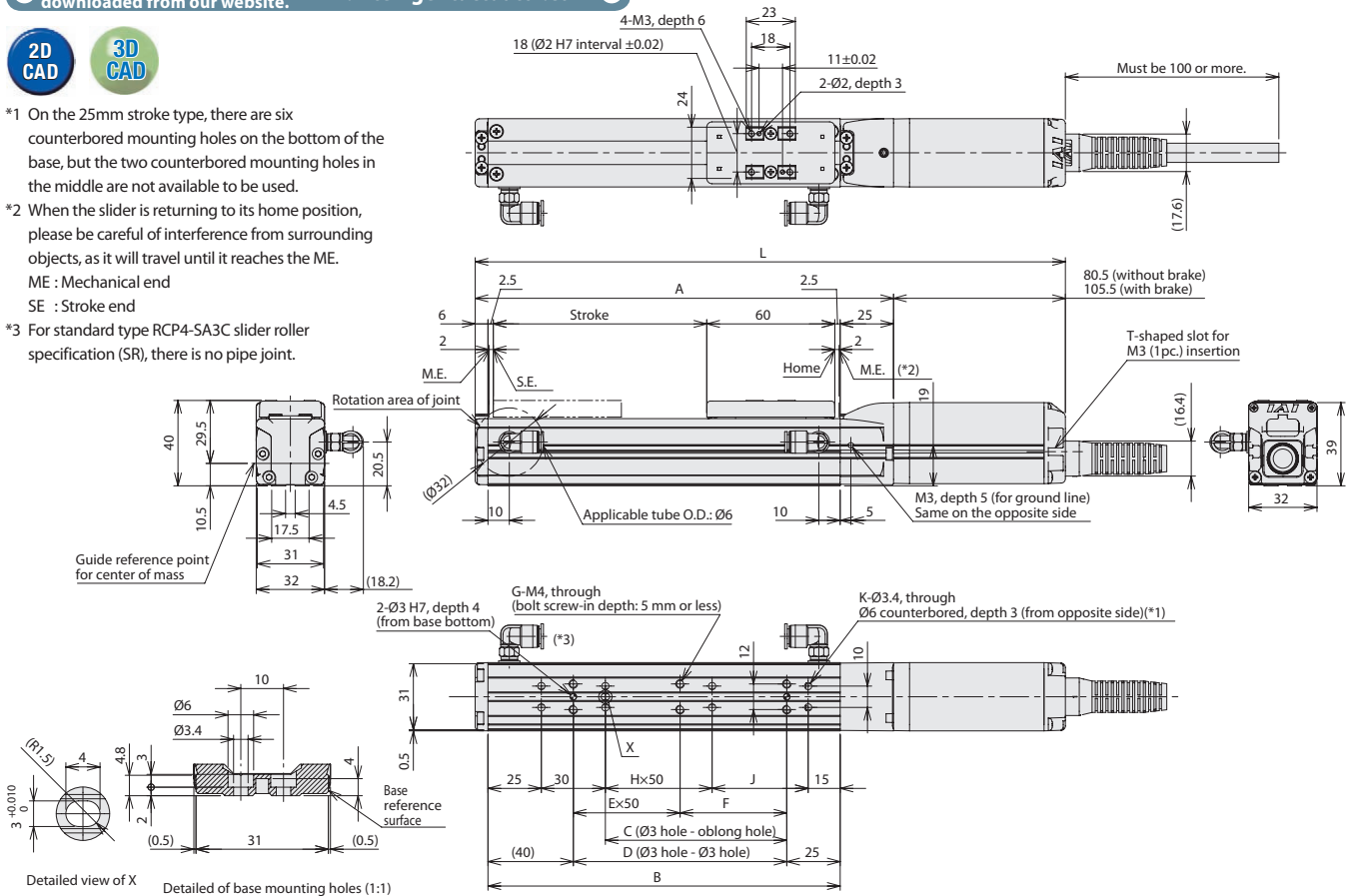

### Home-position Check Sensor Attachment Option

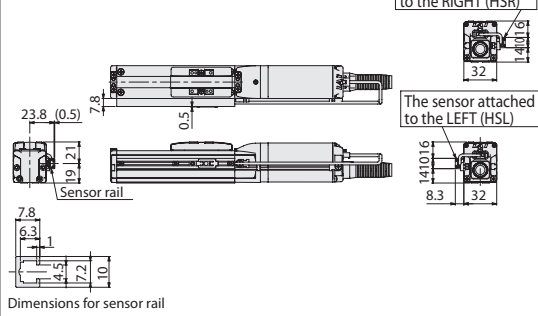

### Dimensions and Mass by Stroke

Stroke	25	50	75	100	125	150	175	200	225	250	275	300	
L	Without Brake	201.5	226.5	251.5	276.5	301.5	326.5	351.5	376.5	401.5	426.5	451.5	476.5
	With Brake	226.5	251.5	276.5	301.5	326.5	351.5	376.5	401.5	426.5	451.5	476.5	501.5
A	121	146	171	196	221	246	271	296	321	346	371	396	
B	90	115	140	165	190	215	240	265	290	315	340	365	
C	10	35	60	85	110	135	160	185	210	235	260	285	
D	25	50	75	100	125	150	175	200	225	250	275	300	
E	0	0	0	1	1	2	2	3	3	4	4	5	
F	25	50	75	50	75	50	75	50	75	50	75	50	
G	4	4	4	6	6	8	8	10	10	12	12	14	
H	0	0	0	1	1	2	2	3	3	4	4	5	
J	(20)	45	70	45	70	45	70	45	70	45	70	45	
K	(6)	6	6	8	8	10	10	12	12	14	14	16	
Mass (kg)	Without Brake	0.51	0.55	0.58	0.61	0.65	0.68	0.71	0.75	0.78	0.81	0.85	0.88
	With Brake	0.6	0.64	0.67	0.7	0.74	0.77	0.8	0.84	0.87	0.9	0.94	0.97

### Applicable Controllers

The RCP4 series actuators can be operated by the controllers indicated below. Please select the type depending to your intended use.

Name	External View	Model Number	Max. Number of Controlled Axes	Maximum Number of Positioning Points	Input Power	Standard Price	Reference Page
Positioner Type High-output Specification		PCON-CA-28P(V)-①-2-0	1	512 point	DC24V	-	Please see individual product catalogs for details
Pulse Train Type High-output Specification		PCON-CA-28PWAI-PL(V)-②-0		-			
Network Type High-output Specification		PCON-CA-28P(V)-③-0-0		768 point			
Solenoid Valve Multi-axis Type (PIO Specification)		MSEP-(V)-④~①-2-0	C: 8 (4 when high-output enabled)	3 point	-		
Solenoid Valve Multi-axis Type (Network Specification)		MSEP-(V)-④~③-0-0	LC: 6 (3 when high-output enabled)	256 point			
Program Control Multi-axis Type		MSEL-PC-1-28P(V)-①-2-4	4	30,000 point	Single-phase AC 100V ~230V	-	
Program Control Multi-axis Type w/Network Board		MSEL-PC-1-28P(V)-③-0-4					
Program Control Multi-axis Type Safety Category Compliant Specification		MSEL-PG-1-28P(V)-①-2-4					
Program Control Multi-axis Type Safety Category Compliant Spec. w/Network Board		MSEL-PG-1-28P(V)-③-0-4					

\*Above MSEL models are for single-axis specification \*① I/O type (NP/PN) \*② Number of axes \*③ Field network specification code  
 \*④ Encoder type: WAI=Incremental / SA=Simple absolute. However, WAI and SA cannot be used together for MSEL \*⑤ C (standard type) or LC (PLC function equipped type)  
 \*⑥ N (NPN specification)/P (PNP specification) code \*The high-output enabled operation is only available when the "High-output setting specification" is selected as an option for the MSEP-C/LC.







## Selection Guideline

### ● Data for Determining Allowable Load for Radial Cylinder RCP4-RA3C/3R

Because the radial cylinder is equipped with a built-in guide structure, a certain amount of load can be applied to the rod without an external guide. Please refer to the diagrams below for the allowable load mass.

Please note that it is necessary to use an external guide when the operational condition exceeds the allowable load.

#### ■ Allowable Load Mass in Horizontal Mount

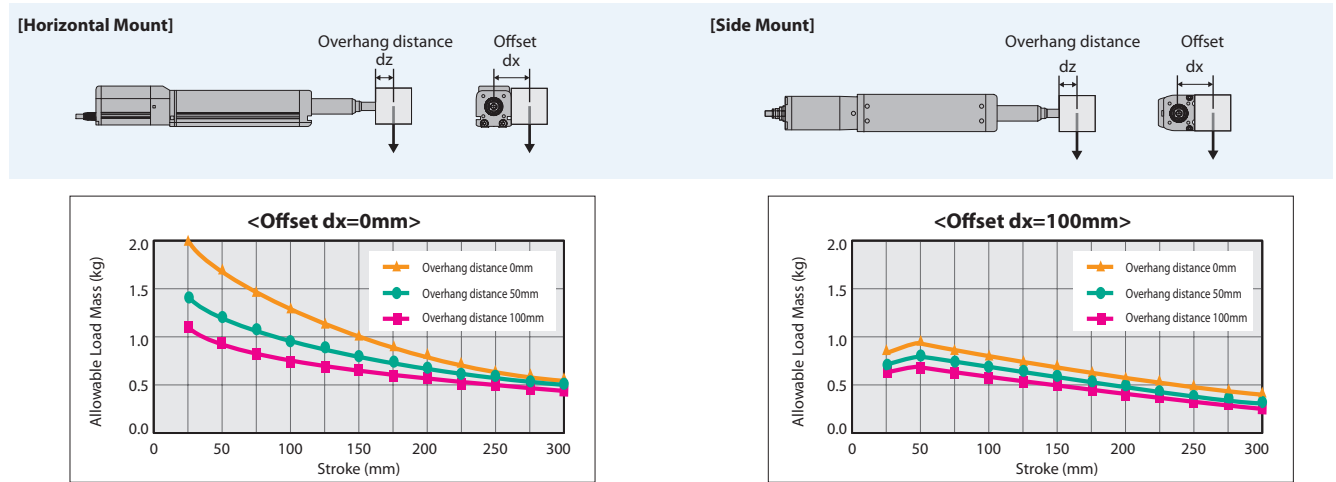

#### ■ Allowable Load Mass in Vertical Mount

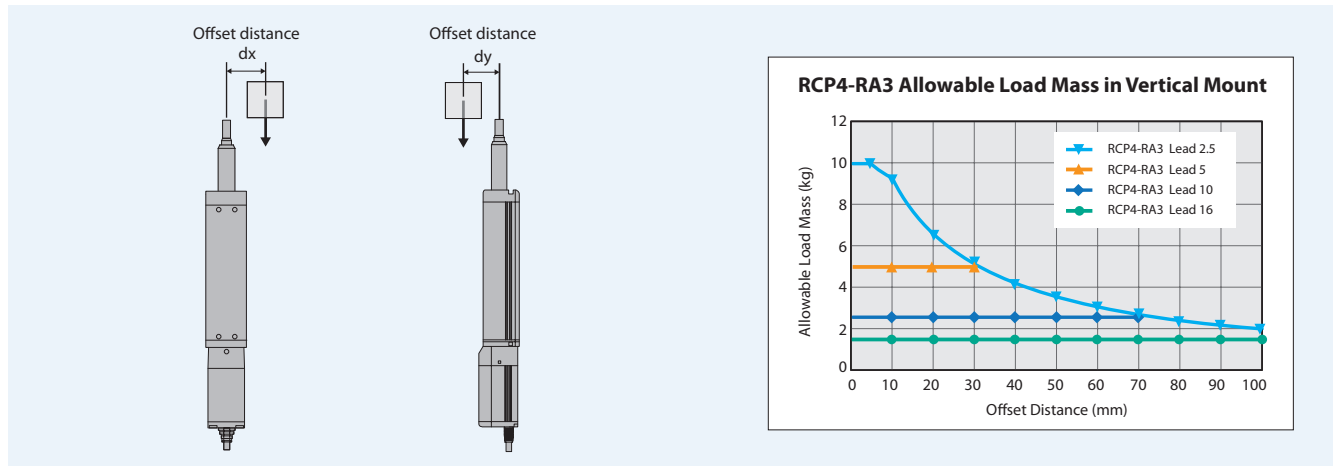

### Maintenance Parts

<b>Model</b>	CB-CAN-MPA□□□	Integrated Motor-encoder Cable	for RCP4-SA3/RA3/RCP4CR-SA3
<b>Number</b>	CB-CAN-MPA□□□-RB	Integrated Motor-encoder Robot Cable	

\*Please indicate cable length (L) in □□□, maximum 20m. e.g.) 080 = 8m

\*Please refer to our ROBO Cylinder General Catalog for details.

### IAI America, Inc.

**USA Headquarters & Western Region (Los Angeles):** 2690 W. 237th Street, Torrance, CA 90505 (800) 736-1712

**Midwest Branch Office (Chicago):** 110 E. State Pkwy, Schaumburg, IL 60173 (800) 944-0333

**Southeast Branch Office (Atlanta):** 1220 Kennestone Circle, Suite 108, Marietta, GA 30066 (678) 354-9470

**www.intelligentactuator.com**

**JAPAN Headquarters:** 577-1 Obane, Shimizu-ku, Shizuoka-shi, Shizuoka, 424-0103, JAPAN

The information contained in this product brochure may change without prior notice due to product improvements.

### IAI Industrieroboter GmbH

Ober der Röth 4, D-65824 Schwalbach am Taunus, Germany

### IAI (Shanghai) Co., Ltd.

Shanghai Jiahua Business Center A8-303, 808, Hongqiao Rd., Shanghai 200030, China

### IAI Robot (Thailand) Co., Ltd.

825 Phairojkijja Tower 7th Floor, Debaratana Rd., Bangna Nuea, Bangna, Bangkok 10260, Thailand